

# GORDON Range EVO



New range of 5 oscillating fans, in table and floor version, equipped with soft-touch and remote controls (depending on the model), with a clean and modern aesthetic that integrates perfectly into both domestic and commercial environments such as shops or offices.



**GORDON EVO 20/8" R**  
Code 60617

**GORDON EVO 20/8"**  
Code 60618



Soft touch  
controls

All Models

**GORDON EVO 30/12"**  
Code 60624

**GORDON EVO C 40/16"**  
Code 60618  
With remote control

Remote control



**GORDON EVO 40/16"**  
Code 60625  
With remote control

- Particularly quiet operation suitable for use in all contexts.
- The 4 or 8 speed fan motor allows you to adapt the intensity of the flow delivered to the needs of the moment.
- The possibility of setting the automatic rotation of the motor fan unit around the vertical axis allows the generation of a pleasant refreshing flow, able to cover a large portion of the space surrounding the fan while avoiding the discomfort of a current constantly facing the occupants.
- The brushless DC motor guarantees low power consumption in the face of high performance.
- The timer for the programmed shutdown of the fan guarantees a further optimisation of consumption.

# GORDON Range EVO



## TECHNICAL FEATURES

- Grille, motor housing and support base in grey painted metal (rose gold only for model GORDON EVO 20/8" R - Cod.60617).
- Central frame, located between the front and rear grilles, made of grey painted plastic material (ABS) (rose gold only for GORDON EVO 20/8" R model - Code 60617).
- Support rod of the motor fan unit in grey painted metal (in aluminium for GORDON EVO C 40/16 Cod. 60623 and GORDON EVO 40/16" Cod. 60625) painted grey (rose gold only for GORDON EVO 20/8" R model - Code 60617).
- GORDON EVO C 40/16" - Code 60623 is equipped with a breakable rod whose central element can be connected to the two ends by means of a quick-coupling mechanism, allowing the height to be adjusted (max 1.69 m) according to needs.
- Touch buttons with display and/or LED lights for displaying the set functions, positioned on the support rod.
- IR remote control, circular in shape, for remote control of GORDON EVO C 40/16" Code 60623 and GORDON EVO 40/16" Cod. 60625.
- Axial impeller directly coupled to a 4 or 8 speed DC (brushless) motor depending on the model, designed to ensure safe and reliable operation.
- Automatic oscillation on the horizontal plane for each product, selectable at 30°, 60° or 90° on GORDON EVO C 40/16" Cod. 60623 and GORDON EVO 40/16" Cod. 60625.
- Possibility of manual adjustment of the fan body on the vertical plane.
- Timer for automatic shutdown, can be set up to a maximum of 4 or 8 hours depending on the model.
- 24V power supply with Italian plug and power cable with a useful length of 180 cm.

PRODUCT	CODE	VOLTAGE ADAPTER INPUT	FREQUENCY	SUPPLY VOLTAGE OUTPUT	W max	A max	MAX FLOW RATE m <sup>3</sup> /h	KG
GORDON EVO 20/8"R*	60617	100-240	50/60 HZ	24	14	0,4	1200	3,5
GORDON EVO 20/8"	60618	100-240	50/60 HZ	24	14	0,4	1200	3,5
GORDON EVO 30/12"	60624	100-240	50/60 HZ	24	22	0,4	2340	5,3
GORDON EVO 40/16"	60625	100-240	50/60 HZ	24	24	0,8	2640	6,5
GORDON EVO C 40/16"	60623	100-240	50/60 HZ	24	24	0,8	2640	13,3

## DIMENSIONS

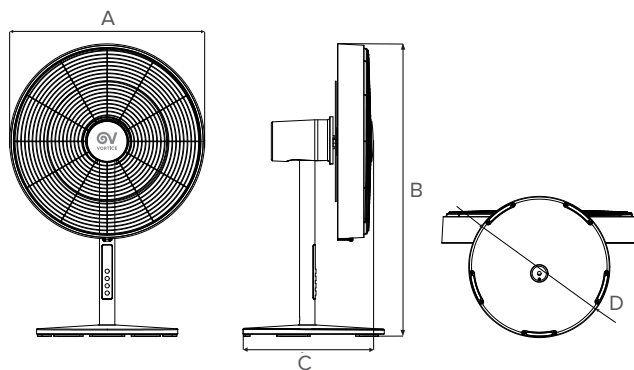

	ØA	B	C	ØD
GORDON EVO 20/8"R* Code 60617	254	461	210	227
GORDON EVO 20/8" Cod.60618	254	461	210	227
GORDON EVO 30/12" Cod.60624	348	565	330	317
GORDON EVO 40/16" Cod.60625	456	684	304	317

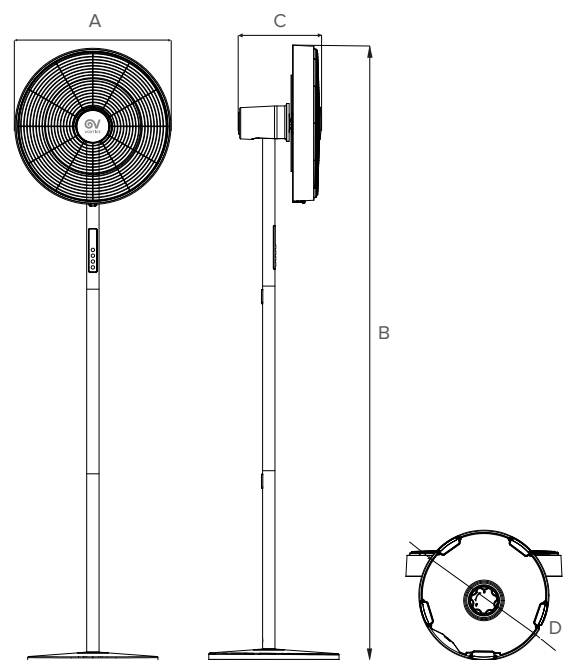

	ØA	B	C	ØD
GORDON EVO C* 40/16" Cod.60623	456	1682	238	360

\*R = rose gold color C\* = column